

WPM SERIES—WELD PREPARATION MILLS

- **Applications: 45° Milling, Chamfering, Roughing, Face Milling, etc**
- This tool designed to utilize 100 deg. corner of a CNMG 432 insert. Recapture unused corners & reduce costs

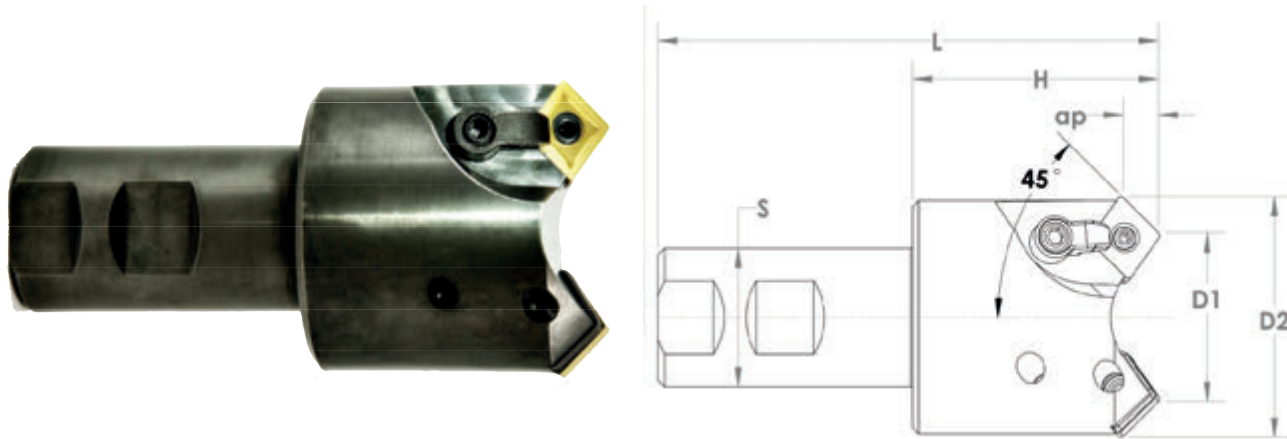

Weldon Shank

Part #	EDP#	(D1)	(D2)	(ap)	(S)	(L)	(H)	Insert	Qty. of Inserts
WPM1500-1250-45002	V12058	1.50"	2.16"	.32"	1.250"	4.50"	2.22"	CNMG 432	2
WPM2000-1250-50003	V12059	2.00"	2.66"	.32"	1.250"	5.00"	2.72"	CNMG 432	3
WPM3000-1250-55004	V12060	3.00"	3.66"	.32"	1.250"	5.50"	3.22"	CNMG 432	4

Shell Mill Mount

Part #	EDP#	(D1)	(D2)	(ap)	(L)	Pilot Dia.	Insert	Qty. of Inserts
WPM3000-1000-2500SM	V12061	3.00"	3.67"	.32"	2.50"	1.000"	CNMG 432	4
WPM4000-1250-2500SM	V12062	4.00"	4.67"	.32"	2.50"	1.250"	CNMG 432	4
WPM5000-1500-3000SM	V12063	5.00"	5.67"	.32"	3.00"	1.500"	CNMG 432	5
WPM6000-1500-3000SM	V12064	6.00"	6.67"	.32"	3.00"	1.500"	CNMG 432	5

Hardware for Weld Preparation Mills

INSERT	LOCK PIN	SHIM	CLAMP	CLAMP SCREW
CNMG 432	F1137	M834	F737	F744